



High performance with optimal cost-performance ratio

# 3200i

[www.fette-compacting.com](http://www.fette-compacting.com)

TECHNOLOGY



COMPETENCE

SERVICE

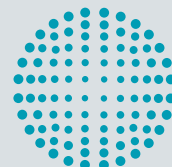

**FETTE  
COMPACTING**

be efficient



The Fette Compacting 3200i is a double sided rotary tablet press suitable for the production of medium to very large batches. It efficiently produces both single- and bi-layer tablets. Maximum flexibility and reliable technology are the distinguishing features of this tablet press – segment technology by Fette Compacting included. In combination with exchangeable turrets, the 3200i guarantees optimal productivity – even when switching between different tablet types. The 3200i combines 100 per cent economic viability with the top technology of the market and technology leader in this market sector.



**TECHNOLOGY** stands for everything we offer in production technology – from tablet presses and capsule filling machines through process equipment to tableting tools and format parts.

**SERVICE** covers all the services related to machines, process equipment and installations such as spare parts supply, plant modernization and technical field service department.

**COMPETENCE** is the overarching idea behind all our process-related services. This includes training, product trials, application and Performance Consulting as well as engineering.

# The principal advantages at a glance

FEATURES	BENEFITS
+ High-performance rotary tablet press, effective in practice	+ Excellent cost / benefit ratio
+ Productive, precise, reliable in operation, robust	+ Best TCO (Total Cost of Ownership) figures
+ Exchangeable die turret	+ Format change over is very fast
+ Exchangeable segment turret	+ High yield, simplified cleaning
+ Large number of stations on the turret	+ Maximum profitability with large batches
+ Operator terminal with 15" touch screen	+ Easy to handle and operate
+ Wide range of accessories and process equipment	+ Remarkable flexibility and range of applications
+ Maximum security and monitoring	+ 24-hour unmanned operation
+ Automatic process monitoring	+ Future-proof basic equipment and software
+ High-quality Fette Compacting standard components	+ Conforms to GMP, GAMP and FDA

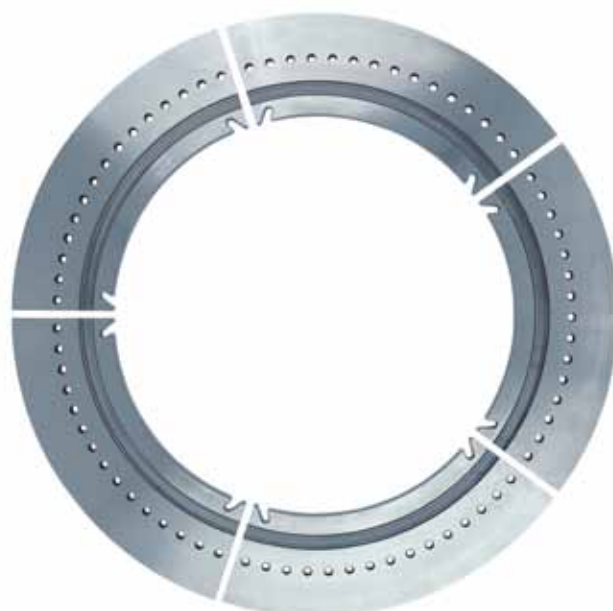

# High productivity through double capacity

## Double tablet output or 2-layer compression products

- + 2 filling units (Fill-O-Matics)
- + 2 pre-compression and main compression stations
- + 2 tablet discharges
- + Up to 110 punch stations in the segment turret
- + Up to 79 punch stations in the die turret

## Extremely high performance figures through optimized design

- + More than 1,5 million tablets/h
- + 24-hour unmanned production
- + Reduction of down-time through the use of a second exchangeable turret or a second segment set
- + Increased yield through segment turret
- + Increase in annual yield through use of the optimum turret in relation to the tablet diameter
- + Shortening of cleaning time through easy accessibility and assembly without special tools
- + Simple and flexible integration into production lines



Two identically sized pre-compression and main compression stations on one turret: double capacity



**Fully modular system, with a wide range in optional process equipments**

- + 3200i tablet press with exchangeable die or segment turret
- + 15" touchscreen with clearly structured user interface
- + Electrical cabinet with real time bus computer

**Accessories and process equipment**

- + Stearate distributors
- + Vertical deduster
- + In-Process control of diameter, thickness, weight and hardness of the tablet
- + Handling system for turret exchanges
- + Wide range of turrets for different types of application
- + In-process control units
- + Tablet distribution units
- + METALCHECK (Testing and sorting of metal contaminated tablets)



# High flexibility with exchangeable segment turrets

## Turret with patented properties

- + Complete die table package is removed, including all cams and punches, patented
- + Adjustment to changing production requirements in very little time
- + Flexible fitting through standardized parts
- + Lower punch secured by patented punch brake against falling out during exchange
- + Turret optionally manufactured of stainless steel or hard-chromed
  - increased resistance to abrasion
  - increased resistance to chemicals
  - reduced surface roughness, smooth surfaces
  - fast cleaning in the washing centre

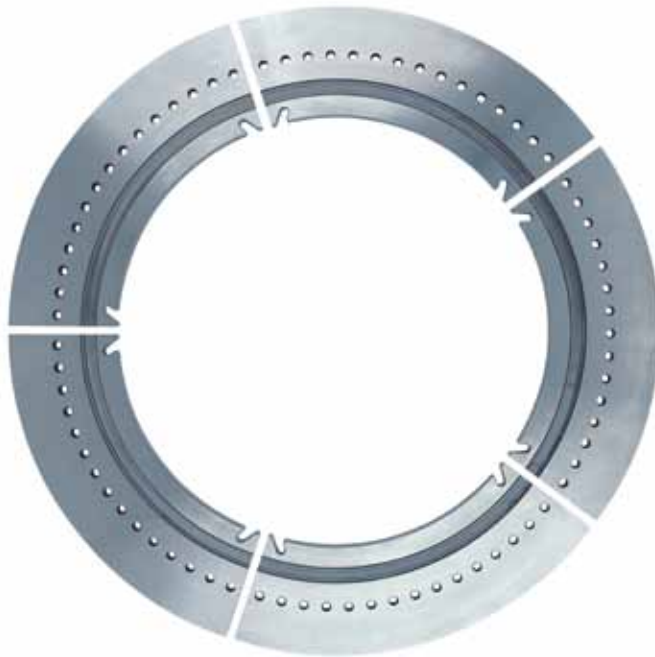

**Great simplification achieves powerful performance potentials**

- + Die table segments for all current Fette Compacting tablet presses
- + All the positive features of conventional exchangeable turrets are retained
- + More stations bring up to 50% increase in yield, depending on tablet diameter
- + Radically shortened fitting time through an 88% reduction in the number of parts
- + Simplified cleaning without the bolts and holes of a standard die plate

- + More than 50% reduction in the loss of product, depending on product properties, through smooth surfaces and the absence of gaps between the die table and the dies
- + Reduced wear through optimum material properties
- + Simplified logistics through fewer parts
- + Lower ejection forces bring higher tablet quality due to smooth surfaces – fast cleaning in the washing centre

**2-layer tablets**

- + 2-layer tablets in a wide range of formats
- + Easy refitting from single- to bi-layer
- + Optimum layer separation



# Optimum operation with the latest hardware and software

## Powerful operating terminal simplifies secure operation

- + 15" touchscreen for an improved overview
- + Powerful industrial PC offers ideal data processing and storage
- + Windows operating system ensures compatibility
- + Uninterruptible power supply protects against data loss
- + Computer-controlled, user-friendly adjustment of the terminal height, patented
- + Service Portal optional available

## Greatly simplified press operation

- + Improved operation with the aid of easily understood icons and buttons
- + Structured diagnostic messages for rectifying malfunctions (expert system)
- + Product-specific magnitudes can be displayed in addition to parameter lists
- + Help texts provide descriptions of parameters and diagnostic messages
- + All production-relevant data are brought together in one view
- + All batch data can be examined
- + Different user levels available for security
- + Full conformity with 21 CFR Part 11

## Detailed documentation

- + Any and all operator inputs and changes are recorded in a change log
- + Process data documentation (production record/result record)
- + Operating status documentation (diagnostic record)
- + Complete overview with automatic analysis
- + Batch record
- + Optional version management





# Maximum security and monitoring with optimized control

## Reliable control

- + Direct control of all motor driven adjustments on the machine
- + Optimal monitoring through data collection from all measuring points
- + High-speed data transfer with the inprocess control and operator interface via Ethernet TCP/IP
- + Clearly structured control loops
- + Highly sensitive measuring points
- + Extremely stable regulation for best tablet quality
- + Incorporation of production-specific data into the control process

- + Precise single-tablet ejection based on compression force ensured
- + Ejection force measurement for production monitoring
- + Measurement of punch tightness
- + Patented monitoring for punch protection
- + Individual quality control, with samples drawn for specific punches
- + Extraction control and monitoring for dust-free compression compartment

## Safety-oriented electrical cabinet

- + Flexible separation of grey and white areas
- + The most up-to-date computer, real-time
- + Total encapsulation of electronic components from surrounding air
- + All assemblies are easily accessible
- + Display of current status via LEDs
- + Calibration unit allows control loop adjustments at any time
- + Easy exchange of computer components
- + Maximum resistance to interference and electromagnetic compatibility
- + Power and control circuitry are strictly isolated
- + Unique cooling design using two separate circulation systems
- + Temperature reduction through standby operation



# Divided structure with encapsulated compression compartment

## Modular mechanical design achieves functional benefits

- + Optimized strength (FEM calculation) for long service life
- + Maximum operating security
- + Ideal working safety
- + Low maintenance costs through long service intervals
- + Modular design with separation into 4 sections:
  - head section
  - compression compartment
  - middle area
  - drive area

## Dust-free head section

- + Plug-in, easily fitted dust extraction
- + Efficient dust extraction with optional vacuum regulation
- + Separate material feed essential for 2-layer tablets
- + Construction of the whole machine completed by
  - sound insulation through sandwich construction and sound-insulating pillars; less than 80 dB, depending on production data
  - all cladding suspended to minimize vibration
  - reinforced window flaps, modified flap seals

## Optimally aligned pressing equipment

- + Precision turret mounting
- + Turret and turret shaft both form-fitting
- + All compression stations of the same construction
- + Adjustment of the upper compression rollers through an eccentric unit
- + Lower compression rollers adjusted by servo motors
- + Compression stations can be moved easily
- + Pre- and main compression rollers have the same dimensions for long dwell times
- + Pre- and main compression force can be up to 100 kN





### Encapsulated compression area

- + GMP conform designed compression compartment
- + Ideal visibility through window flaps with no frames, double-glazed
- + Accessibility from all 4 sides
- + Conforms to the highest GMP standards
- + Easily cleaned and easily exchanged push-in elements shorten fitting times
- + Smooth surfaces for best possible cleaning
- + Strict separation of drive and compression areas
- + Removable, without tools, double-lip seals on the window flaps
- + Filling hopper easily removed by twisting and lowering

### The latest filling system

- + Fill-O-Matic with proven three-chamber system
  - easily dismantled
  - easily cleaned
  - filling and dosage wheel easily exchanged
  - sealing segments matching the tablet diameter brings an enormous reduction in product loss
  - optionally available in washable stainless steel

### Drive chamber optimized for fittings

- + Suspended base plate with vibration insulation
- + High performance torque drive unit
- + Precisely tapered roller bearings



# Single sided production optional

## Continuous production

- + If a packaging machine is attached to each side of a 3200i, it can happen that one of them stops, for reasons associated with the packaging machine, while the other one continues to run. The “single-sided production operation” option makes it possible to continue production at just one of the stations of the tablet press.
- + Advantage when producing single-layer tablets: if the tablet press is fed from two containers, which will almost never become empty at exactly the same time, then when one of the containers has run out it is possible to continue production from the material remaining in the second.
- + Since the 3200i is a symmetrical double press, the “single-sided production operation” function can also be used if components on one side fail, in order to continue operation with the other half.



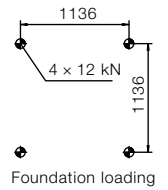
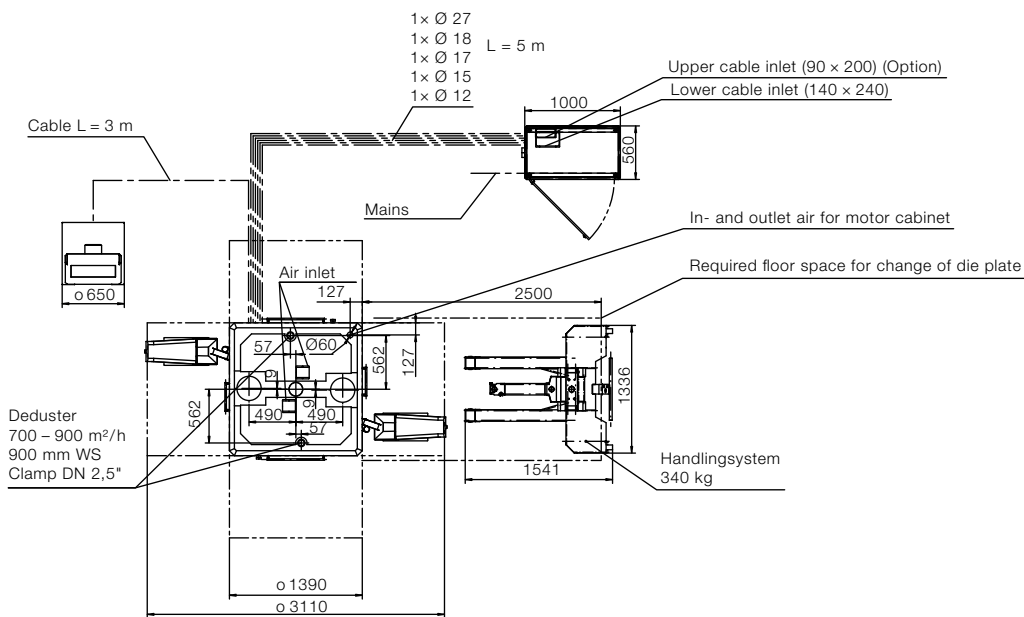
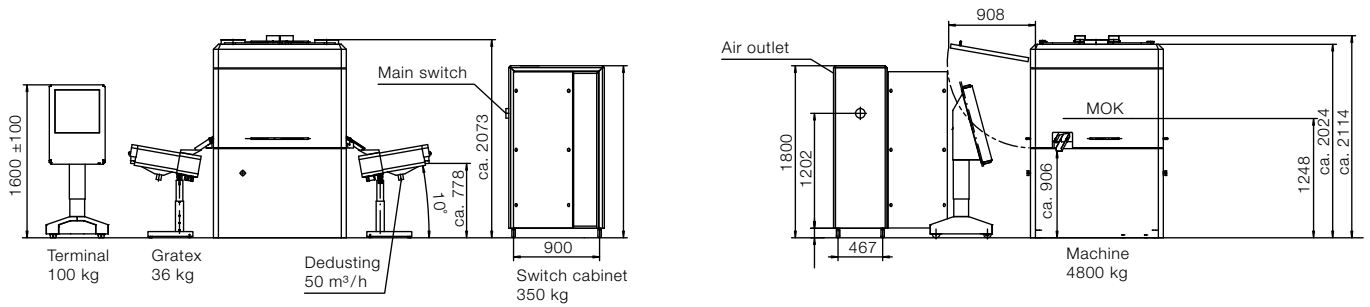

Pressure air min 6 bar for  
Option: air rejectsystem  
Main  
400/440/480 V – 50–60 Hz  
Connection  
4 x 6 mm<sup>2</sup> on floor  
4 x 10 mm cable conduit



# Technical Data

<b>Die (D) / Segments (S)</b>		D	D	D	D	D
<b>Number of punch stations</b>		79	73	61	49	37
<b>Punch type</b>		FS19®/EU19 BBS	FS19®/EU19 TSM19 BB	FS19®/EU19 TSM19 B	EU1"/ EU1"-441 TSM1" D	EU35
<b>Tablet output units/h</b>	min.	142,200	131,400	109,800	88,200	66,600
	max.	1,137,600	1,051,200	878,400	470,400	355,200
<b>Max. compression force 1*</b>	kN	100	100	100	100	100
<b>Max. compression force 2*</b>	kN	100	100	100	100	100
<b>Max. compression force 3*</b>	kN	100	100	100	100	100
<b>Max. compression force 4*</b>	kN	100	100	100	100	100
<b>Max. tablet diameter</b>	mm	11	13	18	25	34
<b>Max. filling depth</b>	mm	20	20	20	22	22
<b>Pitch circle diameter</b>	mm	680	680	680	680	680
<b>Turret rotation speed</b>	min.	min <sup>-1</sup>	15	15	15	15
	max.	min <sup>-1</sup>	120	120	120	80
<b>Die diameter</b>	mm	22	24	30.16	38.1	52
<b>Die-/segment height</b>	mm	22.225	22.225	22.225	23.8	30
<b>Punch shaft diameter</b>	mm	19	19	19	25.35	35
<b>Punch length</b> Upper/lower punch	mm	133.6	133.6 (133.35)	133.6 (133.35)	133.6 (133.35)	133.6
<b>Upper punch insertion depth</b>	mm	1 – 4 (8**)	1 – 4 (8**)	1 – 4 (8**)	1 – 4 (8**)	1 – 4 (8**)
<b>Dimensions</b>	mm	1,390 × 1,390 × 2,024				
<b>Weight</b>	kg	Tablet press 4,200 – 4,500 kg, operating terminal 100 kg, switch cabinet 350 kg				
<b>Electrical supply parameters</b>		Operating voltage 400 – 480 V, 50/60 Hz, power consumption 17 kW				

Theoretical values or technical limits: These can vary in practice, according to product and application.  
Tablet thickness is a size dependent on product and can strongly vary.

\* limited by punch properties; \*\* 2-layer-operation

© by Fette Compacting GmbH

This publication may not be reprinted in whole or part without our express permission.  
All right reserved. No rights may be derived from any errors in content or from typographical or typesetting errors. Diagrams, features and dimensions represent the current status on the date of issue of this leaflet. We reserve the right to make technical changes. The visual appearance of the products may not necessarily correspond to the actual appearance in all cases or in every detail.

S	S	S	S
110	75	55	45
FS12®	FS19®/EU19 TSM19	EU1"/ EU1"-441 TSM1"	EU35
396,000	135,000	99,000	81,000
1,584,000	1,080,000	528,000	432,000
33	100	100	100
33	100	100	100
33	100	100	100
33	100	100	100
11	18	25	34
22	22	22	22
680	680	680	680
15	15	15	15
120	120	80	80
-	-	-	-
25	25	25	25
19	19	25.35	35
133.6	133.6 (133.35)	133.6 (133.35)	133.6
1-4 (8**)	1-4 (8**)	1-4 (8**)	1-4 (8**)

**Fette Compacting GmbH**

Grabauer Strasse 24  
21493 Schwarzenbek  
Germany  
Phone +49 4151 12-0  
Fax +49 4151 3797  
tablet@fette-compacting.com

**Fette Compacting America, Inc.**

400 Forge Way  
Rockaway N.J. 07866  
USA  
Phone +1 973 5868722  
Fax +1 973 5860450  
sales@fetteamerica.com

**Fette Compacting America Latina Ltda.**

Av. Cambacica, 1200 módulo 10  
Parque Imperador  
CEP 13097-160 Campinas/SP  
Brazil  
Phone/Fax +55 19 37969910  
contato@fette-compacting.com.br

**Fette Compacting Mexico, SA de CV**

Adolfo Prieto No. 1638  
Colonia Del Valle Sur  
03100 Mexico, DF  
Mexico  
Phone +52 55 4000 0653  
tablet@fette-compacting.com

**Fette Compacting (China) Co., Ltd.**

8 Phoenix Road Jiangning Development Zone  
211100 Nanjing  
China  
Phone +86 25 52121818  
Fax +86 25 52129951  
fcn@fette-compacting.com

**Fette Compacting Machinery  
(India) Private Limited**

401 to 404, 4th Floor,  
Dynasty Business Park, B wing,  
Near J. B. Nagar Metro station,  
Andheri – Kurla Road,  
J. B. Nagar, Andheri East,  
Mumbai – 400 059  
India  
Phone +91 2242163300  
sales@fette-compacting.in

Competence Centre:  
Plot No S 115, Phase III B  
Verna Industrial Estate  
Verna, Goa 403 722  
India  
Phone +91 832 6690307

**Fette Compacting Asia Pacific Pte Ltd.**

107 Eunos Avenue 3, #01-01  
Singapore 409837  
Singapore  
Phone +65 6592 5654  
Fax +65 6547 1939  
infoasiapacific@fette-compacting.com

**Fette Compacting Ibérica, SL**

Calle Saturno 1  
28760 Tres Cantos  
Spain  
Phone +34 91 8039689  
Fax +34 91 1730017  
fcib@fette-compacting.com

**Fette Compacting et Uhlmann France SAS**

1, Rue du Centre  
93160 Noisy Le Grand  
France  
Phone +33 155 812121  
Fax +33 155 812120  
contact@fette-uhlmann.fr

**Fette Compacting Middle East FZE**

Jebel Ali Free Zone Jafza  
Lobby 14, Office 308  
Dubai  
United Arab Emirates  
Phone +971 48808226  
tablet@fette-compacting.com

[www.fette-compacting.com](http://www.fette-compacting.com)

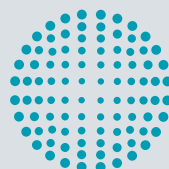

**FETTE  
COMPACTING**  
be efficient